



Standard Test Method for Strength of Sewn or Bonded Seams of Geotextiles¹

This standard is issued under the fixed designation D4884/D4884M; the number immediately following the designation indicates the year of original adoption or, in the case of revision, the year of last revision. A number in parentheses indicates the year of last reapproval. A superscript epsilon (ϵ) indicates an editorial change since the last revision or reapproval.

1. Scope

1.1 This test method covers the determination of the seam strength of geotextiles, using a wide specimen.

1.2 The long term performance of a seaming technique is not addressed by this test method. This test method will provide data to indicate the short term seam strength that can be achieved for each particular geotextile and seam assembly construction. To assess the long term performance of a seaming technique, it is possible to use Practice [D6389](#), using this test method to determine the anticipated strength reduction in the initial, short term wide-width tensile strength (Test Method [D4595](#)) results.

1.3 The values stated in either SI units or inch-pound units are to be regarded separately as standard. The values stated in each system may not be exact equivalents; therefore, each system shall be used independently of the other. Combining values from the two systems may result in non-conformance with the standard.

1.4 *This standard does not purport to address all of the safety concerns, if any, associated with its use. It is the responsibility of the user of this standard to establish appropriate safety and health practices and determine the applicability of regulatory limitations prior to use.*

2. Referenced Documents

2.1 ASTM Standards:²

[D76/D76M Specification for Tensile Testing Machines for Textiles](#)

[D1776 Practice for Conditioning and Testing Textiles](#)

[D1777 Test Method for Thickness of Textile Materials](#)

[D4439 Terminology for Geosynthetics](#)

[D4595 Test Method for Tensile Properties of Geotextiles by the Wide-Width Strip Method](#)

¹ This test method is under the jurisdiction of ASTM Committee [D35](#) on Geosynthetics and is the direct responsibility of Subcommittee [D35.01](#) on Mechanical Properties.

Current edition approved May 1, 2014. Published June 2014. Originally approved in 1989. Last previous edition approved in 2014 as [D4884/D4884M – 14](#). DOI: 10.1520/D4884_D4884M-14A.

² For referenced ASTM standards, visit the ASTM website, www.astm.org, or contact ASTM Customer Service at service@astm.org. For *Annual Book of ASTM Standards* volume information, refer to the standard's Document Summary page on the ASTM website.

[D6389 Practice for Tests to Evaluate the Chemical Resistance of Geotextiles to Liquids](#)

[E178 Practice for Dealing With Outlying Observations](#)

[E691 Practice for Conducting an Interlaboratory Study to Determine the Precision of a Test Method](#)

2.2 *Federal Standard*.³

[Fed. Std. No. 751a Stitches, Seams, and Stitchings](#)

3. Terminology

3.1 Definitions:

3.1.1 *adhered seam, n*—in geotextiles, a seam made by the application of an adhesive.

3.1.2 *cross-machine direction*—the direction in the plane of the geotextile perpendicular to the direction of manufacture.

3.1.3 *geotextile, n*—a permeable geosynthetic comprised solely of textiles.

3.1.4 *linear density, n*—mass per unit length; the quotient obtained by dividing the mass of a fiber or yarn by its length.

3.1.5 *machine direction*—the direction in the plane of the geotextile parallel to the direction of manufacture.

3.1.6 *seam allowance, n*—the width of geotextile used in making a seam assembly, for sewn seams bounded by the edge of the geotextile and the furthest stitch line, and for thermally bonded seams bounded by the edge of the geotextile and the furthest seam edge.

3.1.6.1 *Discussion*—In geotextiles, the distance from the selvage or turned edge of the geotextile to the edge of the seam.

3.1.7 *seam assembly, n*—the unit obtained by joining geotextile with a seam, including details such as geotextile direction(s), seam allowance, seam width, seam type, speed, and if sewn—sewing threads used and number of stitches per unit length, needle type and size, and if adhered – adhesive used, amount of adhesive in weight per unit area, overlap dimension and one or both sides with adhesive applied and so forth.

3.1.8 *seam design engineering, n*—the procedures used to select a specific thread, a specific stitch type, and a specific seam type to achieve the required seam strength of a sewn seam and the procedures used to select a specific seam width,

³ Available from DLA Document Services, Building 4/D, 700 Robbins Ave., Philadelphia, PA 19111-5094, <http://quicksearch.dla.mil>.

specific seam bonding temperature, a specific seam speed and pressure to achieve the required seam strength of a thermally bonded seam and the type and amount of adhesive, overlap dimension and whether the adhesive was applied to one or both sides of the overlap to achieve the required seam strength of an adhered seam.

3.1.9 *seam interaction, n*—the result of combining specific textile, a specific stitch type, and a specific seam type for a sewn seam, the result of combining specific textile, a specific seam width, a specific seam speed, and applied pressure for a thermally bonded seam and the type and amount of adhesive, overlap dimension and whether the adhesive was applied to one or both sides of the overlap to achieve the required seam strength of an adhered seam.

3.1.10 *seam strength, n—for geotextiles*, the maximum resistance, measured in kilonewtons per metre, of the junction formed by stitching together two or more planar structures.

3.1.11 *seam type, n—in sewn geotextiles*, an alphanumeric designation relating to the essential characteristics of geotextile positioning and rows of stitching in a specific sewn geotextile seam (see Fed. Std. No. 751a).

3.1.11.1 *Discussion*—The first two letters of the designation show seam type; the third and subsequent letter specify a particular mating alignment; the number designation indicates the number of rows of stitches.

3.1.12 *seam weld, n*—the process by which a seam is formed through the thermal bonding of separate layers of geotextile.

3.1.13 *selvage, n*—the woven edge portion of a geotextile parallel to the machine direction.

3.1.13.1 *Discussion*—The edge of a nonwoven geotextile cannot be easily distinguished to determine either the machine or cross-machine direction.

3.1.14 *sewing thread, n*—a flexible, small diameter yarn or strand, usually treated with a surface coating, or lubricant, or both, intended to be used to stitch one or more pieces of material or an object to a material.

3.1.15 *sewn seam, n—in sewn geotextiles*, a series of stitches joining two or more separate plies of a material or materials of planar structure such as a textile geotextile.

3.1.16 *stitch, n*—the repeated unit formed by the sewing thread in the production of seams in a sewn geotextile (see Fed. Std. No. 751a).

3.1.17 *thermally bonded seam, n—in geotextiles*, a seam made by the application of thermal energy.

3.1.18 For definitions of other terms relating to geotextiles, refer to Terminology [D4439](#).

4. Summary of Test Method

4.1 A seam, 200 mm [8 in.] wide is gripped across the entire width in the clamps of a tensile testing machine, operated at a prescribed rate of extension, applying a longitudinal (perpendicular) force to the specimen until the seam or geotextile ruptures.

5. Significance and Use

5.1 As explained in Test Method [D4595](#), narrow geotextile specimens demonstrate the tendency to contract (neck down) in the gage area when under stress. The wider width specimen will minimize this phenomenon in seams during strength testing. The results achieved in this test method can more accurately correlate to the seam strength values anticipated in the field.

5.2 This test method can be used to measure the seam strength of geotextiles, and may also be used for acceptance testing of commercial shipments of geotextiles.

5.3 This test method can be used to help determine seam design engineering for the geotextiles being evaluated.

5.4 This test method is not intended to address long term performance of a seam nor any of its components such as the thread or the adhesive. However, it can be used as an index value to monitor the behavior of a seam exposed to any particular exposure, in example as part of an effort to assess its long term performance.

6. Apparatus

6.1 *Tensile Testing Machine*, must be of the constant-rate-of-extension (CRE) type, conforming to Specification [D76/D76M](#) and equipped with a recorder having an adequate pen response or interfaced computer to record the load elongation curve. The machine must be set to a rate of extension of 10 ± 3 %/min.

6.2 *Clamps*—The clamps shall be wide enough to grip the entire width of the specimen and have the appropriate clamping power to hold the test specimen in place without crushing (damaging) the geotextile.

6.2.1 Caution must be taken to ensure that the type of clamp used is adequate for the seam strength being measured.

6.3 *Size of Jaw Faces*—Each clamp shall have a clamping face wider than the width of the specimen, typically 225 mm [8.86 in.] or larger, and a minimum of 50 mm [2 in.] in the direction of the applied force. The size of jaw faces does not apply if roller clamps are used.

7. Sampling for Acceptance Testing and Number of Specimens

7.1 *Division into Lots and Lot Sample*—Divide the material into lots and take a lot sample as described in an applicable material specification, or as agreed upon between the purchaser and the supplier. In the absence of an applicable material specification or prior agreement between the purchaser and the supplier, sampling and testing intervals should be agreed upon between the purchaser and the supplier.

7.1.1 When the installation project requires that seams are made in both the machine and cross-machine directions, the number of samples and the subsequent specimens will increase proportionately.

7.2 *Laboratory Samples*—At a laboratory sample, cut a minimum of two swatches of geotextile from each of the lot units selected for testing. The swatches must be long and large enough to permit seaming and selection of representative

sections of seams for specimen preparation, such as, a minimum of 2000 mm [79 in.] in length and a minimum of 300 mm [12 in.] in width. The lengthwise direction of these swatches must be cut from opposite ends and opposite sides of the lot sample rolls and should be parallel to the direction in which the seam will be made.

7.2.1 When seams are made in both the machine and cross-machine direction, it is suggested that some type of special color identification marking be used to distinguish one from the other.

7.2.2 These swatches are then joined using the best seam engineering techniques determined by the purchaser and the supplier to achieve seam interaction.

7.2.3 It will be necessary to cut a sufficient number of swatches for both wet and conditioned tests.

7.3 Test Specimens:

7.3.1 Number of Specimens—In the absence of an applicable specification or prior agreement between the purchaser and the supplier, prepare at least six test specimens from the laboratory samples.

7.3.2 Test Specimen Size—Prepare test specimens from the laboratory sample. Each specimen should be approximately 250 mm [10 in.] wide with a stitch line in the center for sewn seams or approximately 200 mm [±8 in.] wide with the seam weld in the center for thermally bonded or adhered seams running parallel to either the machine or cross-machine directions as shown in Fig. 1(a) for sewn seams, Fig. 1(b) for thermally bonded seams or Fig. 1(c) for adhered seams.

7.3.2.1 Cut this wider specimen for sewn seams as shown in Fig. 1(a) to achieve a final test specimen width of 200 mm [8 in.]. When removing the shaded area from a specimen as shown in Fig. 1(a), the angles between the 25-mm extensions which are parallel to the seam and that section of the specimen having a finished width of 200 mm is 90°.

7.3.2.2 For some seaming patterns, cutting the thread may lead to a loss of the integrity of the seam, and thus to an underestimation of the seam strength. For these patterns, some means shall be used to lock the thread in place, such as using glue, or mechanically locking the thread on both ends of the seam by un-sewing the seam over a maximum length of 25 mm, without damaging the sewing thread, in order to have at

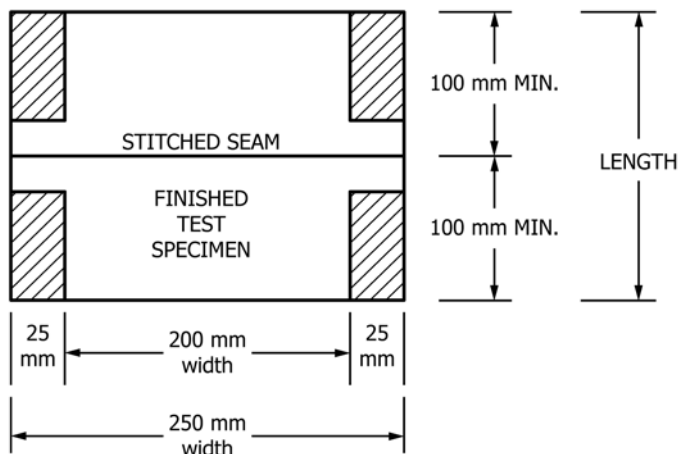

FIG. 1 (a) Test Specimen Preparation for Sewn Seam (Front View)

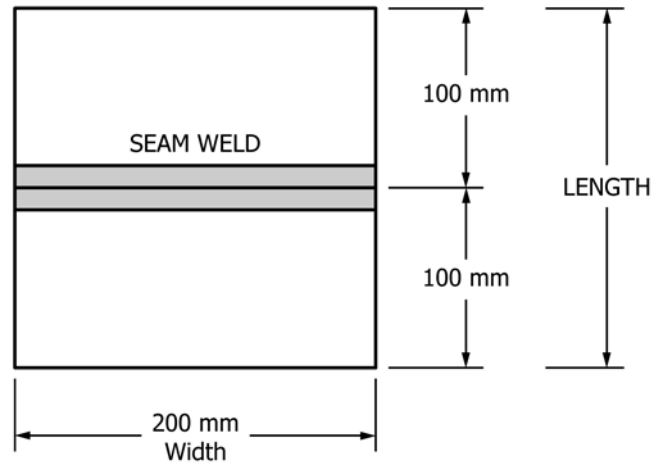
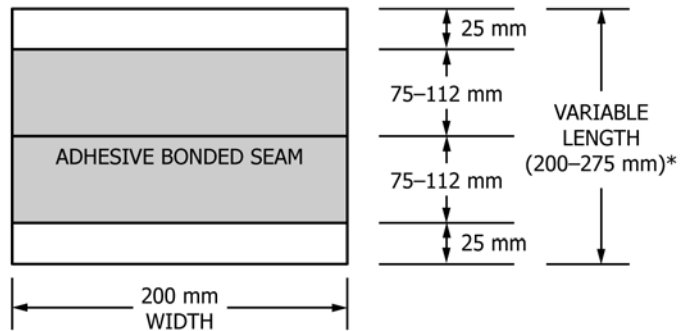

FIG. 1 (b) Test Specimen Preparation for Thermally Bonded Seam (Front View) (continued)



*Where adhered seam overlap is 150 mm [6 in.] adhered seam specimen length is 200 mm; where adhered seam overlap is 225 mm [9 in.], adhered seam specimen length is 275 mm [11 in.].

FIG. 1 (c) Test Specimen Preparation for Adhesive Bonded Seam (Front View) (continued)

least 200 mm of intact seam centered in the axis of the specimen. Both upper and lower threads of the seam shall then be tied together to avoid any further modification to the structure of the stitch during the test.

8. Sampling of Field Seams and Factory Seams

8.1 The evaluation of field seams and factory seams will be made by taking samples at the stipulated intervals directed in Table 1 unless otherwise stated.

NOTE 1—To prevent the unnecessary waste of geotextile or impede the

TABLE 1 Seam Quality Control Sampling Requirements

Total Length of Field ^A Seams for Project, m [yd]	Sample Interval ^B Requirements, m [yd]
Up to 10 000 [Up to 11 000]	1000 [1100]
10 001 to 150 000 [11 000 to 165 000]	1500 [1666]
150 000 and up [165 000 and up]	2000 [2200]

^A Total length of field seams for project is the sum of all machine direction and cross-machine direction seams required to effect installation of geotextile(s).

^B Samples will be taken at stipulated intervals along the total length of the field seams. The number of such intervals will be rounded to the next higher whole number.

installation, it should be agreed upon between the supplier and the purchaser that all seam samples can be taken from alternate sides of panels at or near the end of the rolls.

8.2 The lengthwise direction of these swatches should be parallel to the direction of the seam, either in the machine or cross-machine direction.

8.2.1 It will be necessary to cut additional swatches for both wet and conditioned tests to be performed.

8.3 Prepare test specimens as specified in 7.3.2.

9. Conditioning

9.1 Bring the specimens to moisture equilibrium in the atmosphere for testing geotextiles. Equilibrium is considered to have been reached when the increase in mass of the specimen in successive weighing made at intervals of not less than 2 h does not exceed 0.1 % of the mass of the specimen. Unless the purchaser and the supplier agree otherwise, bring the test specimens to moisture equilibrium starting with the condition in which they were received.

9.1.1 Certain fibers may exhibit slow moisture equalization rates when received in a wet condition. When this is known, the purchaser and the supplier may agree to use a preconditioning cycle as specified in Practice D1776.

NOTE 2—It is recognized that, in practice, geotextile materials are frequently not weighted to determine when moisture equilibrium has been reached. While such a procedure cannot be accepted in cases of dispute, it may be sufficient in routine testing to expose the material to the standard atmosphere for testing for a reasonable period of time before the specimens are tested. A time of at least 24 h has been found acceptable in most cases.

10. Wet Testing (optional)

10.1 Wet field conditions require that one test should be performed with a wet-conditioned specimen and compared with dry specimen results. If significant variations exist, wet conditioning should be considered for all test specimens by the supplier and the purchaser.

10.1.1 Specimens to be tested in the wet condition must be immersed in water maintained at a temperature of $21 \pm 2^\circ\text{C}$ [$70 \pm 4^\circ\text{F}$]. In the absence of an applicable conditioning specification or prior agreement between the purchaser and the supplier, immersion of 24 h will be required to effect complete wet conditioning.

10.1.1.1 It may be necessary or advisable to add 0.05 % of a nonionic neutral wetting agent to the water to obtain thorough wetting.

10.1.1.2 A test of any immersed specimen must be completed within 20 min after removal from the water.

10.2 When conducting wet-conditioned tests of field seam specimens, it will be necessary to immerse these specimens as required in 10.1.1 to effect wetting. Perform a series of at least ten wet-conditioned tests on test specimens from the geotextile to be evaluated. Prepare the test specimens as a single group from this same production lot and assign them in equal numbers, at random, for testing.

11. Procedure

11.1 *For All Specimens*—As described in 7.3, test specimens are cut from laboratory samples to a specimen size shown in either Fig. 1(a) or Fig. 1(b).

11.1.1 With geotextile facing in the open front position (as shown in Fig. 1(a) and Fig. 1(b), so that the stitch line or seam weld width furthest from the selvage is clearly visible, carefully draw one parallel line on both sides of the seam, 50 mm [2 in.] from the edge of the seam weld width on a thermally bonded seam that is used to determine seam allowance or 25 mm [1 in.] from the edge of the seam overlap for an adhered seam. These parallel lines designate the gage area. The seam must be centered, as much as possible, between these lines so that the seam is parallel to the clamps.

11.1.2 The length of the specimen perpendicular to the seam depends upon the type of clamps being used. It must be long enough to extend through the full length of both clamps in a manner so that the gage length of 50 mm [2 in.] on each side of the center of the seam is not reduced (see Fig. 2(a), Fig. 2(b), and Fig. 2(c)).

11.1.3 For each test specimen of sewn seams, determine the stitch density by counting the number of stitches available over the 200 mm width of each test specimen, expressed in stitches per centimetre or stitches per inch.

11.1.4 For adhesive and thermally bonded seams, measure the thickness in the bonded area as specified in Test Method D1777.

11.1.5 For adhesive and thermally bonded seams, measure the bonded overlap dimension.

11.2 *Insertion of Specimen in Clamps*—Mount the seam specimen centrally in the clamps facing in the open front position as described in 11.1.1. Do this by positioning the two lines previously drawn in 11.1.1 as close as possible to the inside edges of the lower and upper jaw with the seam centered. The seam and gage lines must be parallel to the clamps as shown in Fig. 2(a), Fig. 2(b), and Fig. 2(c). When testing, either the machine or cross-machine direction seam strength, tension on the specimen should be uniform across the width.

11.3 *Measurement of Seam Strength*—Start the tensile testing machine and continue the procedure until the seam or geotextile ruptures. Stop the machine and reset to the initial gage position.

11.3.1 During application of the load to the seam specimen, observe and record the maximum force to rupture of the seam

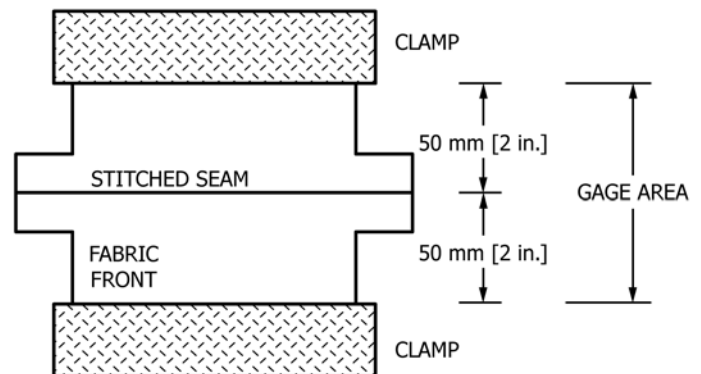

FIG. 2 (a) Placement of Generic Seam in Clamps for Sewn Seam (Front View)

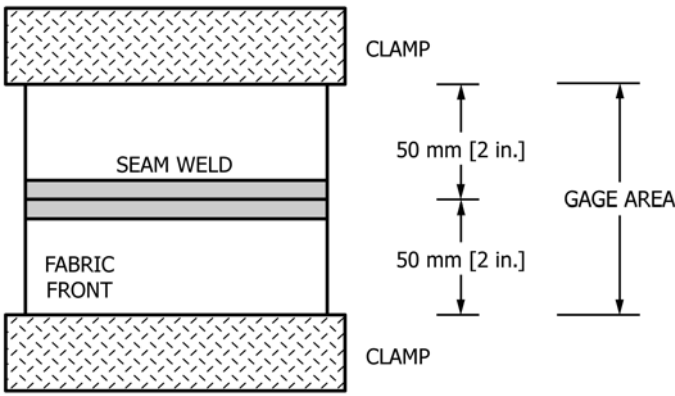
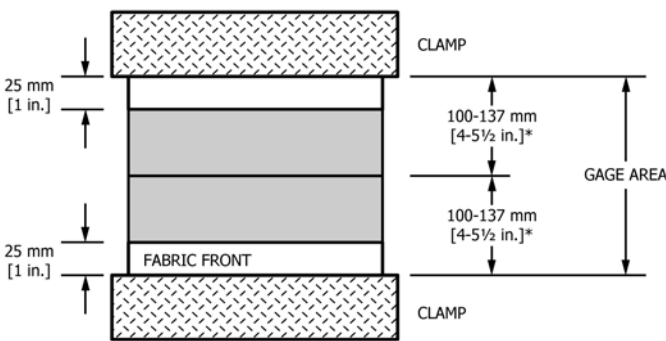

FIG. 2 (b) Placement of Generic Seam in Clamps for Thermally Bonded Seam (Front View) (continued)



*Where adhered overlap is 150 mm [6 in.], gage length is 203 mm [8 in.]; where adhered overlap is 225 mm [9 in.], gage length is 275 mm [11 in.].

FIG. 2 (c) Placement of Generic Seam in Clamps for Adhesive Bonded Seam (Front View) (continued)

as read directly from the testing machine. Observe and record whether the seam rupture is caused by geotextile yarn rupture, sewing thread rupture, seam weld edge break, adhesive slippage, geotextile yarn slippage, tear-type geotextile yarn rupture, or a combination thereof.

11.3.2 Record the time to break for all specimens.

NOTE 3—Record and report the test results in either machine or cross-machine direction separately.

11.4 *Discarding Data*—Causes for failure which yield break strength values that are significantly below average include, but are not limited to, specimen slippage in jaws, breaks at the edge of (or in) the jaws, and faulty operation of test equipment.

11.4.1 Outlying data points should be determined in accordance with Practice E178.

11.4.2 The decision to discard the results of any failing specimen must be agreed upon between the purchaser and the supplier. In the absence of any such agreement, these specimens and results shall be retained.

11.4.2.1 Any decision to discard the results of a break strength test shall be based on observation of the specimen during the test. When a determination is significantly below the average for the set of specimens and there is physical evidence that the specimen was damaged or that the test was carried out improperly, disregard the test determination and test another specimen. The reason for disregarding this determination must be reported.

11.4.3 When a geotextile manifests any slippage in the jaws, or if more than 24 % of the specimens break at a point within 5 mm [0.20 in.] of the edge of the jaw, then the jaws may be padded, the geotextile may be coated under the jaw face area, or the surface of the jaw face may be modified. If any of these changes are used, state the modification in the report.

11.4.4 Another means of distinction between clamp slippage and geotextile slippage within the specimen is by measuring 75 mm [3 in.] between both the upper and lower gage lines, and along the center axis between the upper and lower clamp.

11.4.4.1 Draw two parallel lines (using a different color than the gage lines), attach a device that measures elongation either mechanically or electronically, and record the change in length between these two lines (see Fig. 3(a) and Fig. 3(b)).

12. Calculation

12.1 *Seam Strength*—Calculate the maximum seam strength of individual seam specimens, that is, the maximum force in kilonewtons per metre to cause a specimen to rupture as read directly from the testing instrument using Eq 1:

$$S_f = \frac{F_f}{W_s} \quad (1)$$

where:

S_f = seam strength, kN/m,
 F_f = observed breaking force, kN, and
 W_s = specified specimen width, m.

13. Report

13.1 Report that the specimens were tested in accordance with this test method. Describe the material or product sampled and the method of sampling used, including any available information such as the type of fabric, yarn, type of stitch, etc.

13.2 Report all of the following applicable items in the machine direction or cross-machine direction, or both, of the seams tested for both dry and wet conditions, to include wet conditioning time requirements:

13.2.1 Seam strength in kilonewtons per metre for each specimen tested and the average of the results using Eq 1,

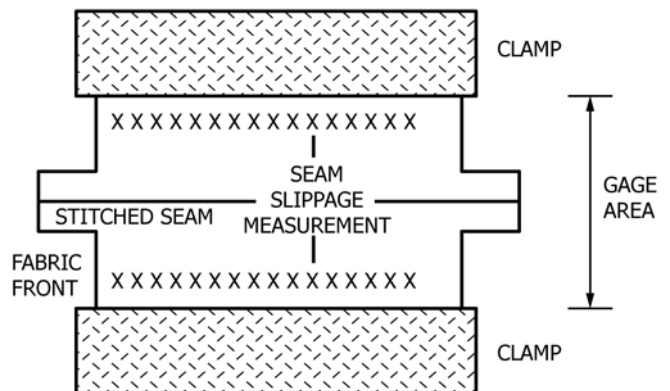

FIG. 3 (a) Gage Area for Measurement of Geotextile/Seam Slippage of Sewn Seam Specimen

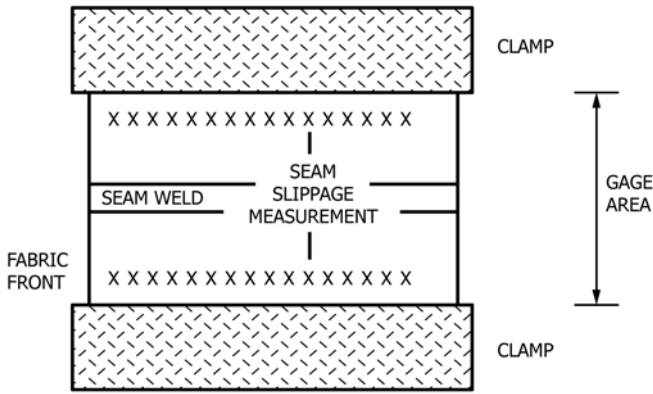

FIG. 3 (b) Gage Area for Measurement of Geotextile/Seam Slippage of Adhesive or Thermally Bonded Seam Specimen
(continued)

13.2.2 For sewn seam, sewing machine used, type, thickness and strength of thread, stitch density of each specimen and average,

13.2.3 For bonded seams, thickness in the bonded area,

13.2.4 For adhered seams, adhesive type, adhesive weight per unit area applied, and adhesive overlap dimension,

13.2.5 Time required for rupture to occur,

13.2.6 Type of failure (geotextile, seam failure, or other),

13.2.7 If requested, the standard deviation or coefficient of variation, or both, of any of the properties,

13.2.8 Number of specimens tested in each direction,

13.2.9 Type of clamp and, if applicable, size of jaw faces used,

13.2.10 Type of padding used in jaws, modification of specimens gripped in the jaws, or modification of jaw faces, if used,

13.2.11 If requested, the make and model of testing machine and full-scale load range used for testing,

13.2.12 Any modification of procedure to include discarded data, and

14. Precision and Bias⁴

14.1 *Precision*—The precision of this test method was established using an interlaboratory study designed to comply with the requirements of Practice E691.

14.1.1 The coefficient of variation of the 95 % repeatability limit was 12 %.

14.1.2 The coefficient of variation of the 95 % reproducibility limit was 32 %.

14.2 *Bias*—This test method has no bias since the values of these properties can be defined only in terms of a test method.

15. Keywords

15.1 adhesive bonded seam; geotextile; seam weld; sewn seam; thermally bonded seam

⁴ Supporting data have been filed at ASTM International Headquarters and may be obtained by requesting Research Report RR:D35-1001. Contact ASTM Customer Service at service@astm.org.

ASTM International takes no position respecting the validity of any patent rights asserted in connection with any item mentioned in this standard. Users of this standard are expressly advised that determination of the validity of any such patent rights, and the risk of infringement of such rights, are entirely their own responsibility.

This standard is subject to revision at any time by the responsible technical committee and must be reviewed every five years and if not revised, either reapproved or withdrawn. Your comments are invited either for revision of this standard or for additional standards and should be addressed to ASTM International Headquarters. Your comments will receive careful consideration at a meeting of the responsible technical committee, which you may attend. If you feel that your comments have not received a fair hearing you should make your views known to the ASTM Committee on Standards, at the address shown below.

This standard is copyrighted by ASTM International, 100 Barr Harbor Drive, PO Box C700, West Conshohocken, PA 19428-2959, United States. Individual reprints (single or multiple copies) of this standard may be obtained by contacting ASTM at the above address or at 610-832-9585 (phone), 610-832-9555 (fax), or service@astm.org (e-mail); or through the ASTM website (www.astm.org). Permission rights to photocopy the standard may also be secured from the Copyright Clearance Center, 222 Rosewood Drive, Danvers, MA 01923, Tel: (978) 646-2600; http://www.copyright.com/